



TECHNICAL GUIDE

**SINGLE PACKAGE
HEAT PUMP / ELECTRIC HEAT
16 SEER – R-410A – 460V - 3 PHASE
3 THRU 5 NOMINAL TONS
MODELS: PHE6*36 THRU 60**



Due to continuous product improvement, specifications are subject to change without notice.

Visit us on the web at www.upgnet.com and www.york.com

Additional rating information can be found at: www.ahridirectory.org

WARRANTY SUMMARY*

Standard 1-Year limited parts warranty.

Standard 5-Years limited compressor warranty.

*See limited warranty certificate in User's Information Manual for details.

DESCRIPTION

These packaged cooling/heating heat pumps are designed for outdoor installation. Only utility and duct connections are required at the point of installation.

FEATURES

- **Operating Efficiency** - The PHE6 heat pump models are rated at 16.0 SEER, 12.5 EER and 8.2 HSPF per DOE procedures and are AHRI certified. All PHE6 models utilize multi-stage compressors for maximum comfort and efficiency.
- **On Site Flexibility** - All model sizes use a compact design cabinet in one footprint. Field convertible duct connections from side shot to down shot allows the installer to have greater flexibility with less inventory.
- **Lower Installation Cost** - Installation time and costs are reduced by easy power and control wiring connections. All units are completely wired, charged with R-410A refrigerant and tested prior to shipment. Test stations using a state-of-the-art computerized process system are used to insure product quality. Refrigerant charge and component part numbers are verified via computers during assembly. Vital run test statistics such as system pressure, motor currents, air velocity and temperature, unit vibration, and gas system safeties are monitored and recorded by the system to insure unit performance. Equal size side supply and return duct connections allow easy connection of ducts to match low crawl spaces without transition pieces.
- **Utility Connections Made Easy** - Electric utility access provided through the bottom or the side of the unit. Utility connections can be made quickly and with a minimum amount of field labor. A field supplied and field installed electrical disconnect switch must be installed.
- **Convertible Airflow Design** - The bottom duct openings are covered when they leave the factory, ready to be used for a side supply/side return application. If a bottom supply/bottom return application is desired, simply remove the two panels from the bottom of the unit and place them in the side supply/side return duct openings. No panel cutting is required and no accessory panel is necessary. Convertible airflow design allows maximum field flexibility and minimum inventory.
- **Condensate Pan** - A corrosion-resistant, long-lasting, water-tight pan is positioned below the indoor coil to collect and drain all condensate, preventing build-up of stagnant condensate. The condensate pan conforms to ASHRAE 62-89 standards (Ventilation for Acceptable Indoor Air Quality).
- **Condensate Drain** - The 3/4 inch NPT female connection is rigidly mounted to assure proper fit and leak tight seal.
- **Durable Finish** - The cabinet is made of G90 galvanized steel with a powder paint coating for appearance and protection. The pre-treated galvanized steel provides a better paint-to-steel bond, which resists corrosion and rust creep. Powder paint finish insure less fading when exposed to sunlight, and provides superior corrosion resistance (1000 hour salt spray tested).

Continued on next page.

- **Full Perimeter Base Rails** - The easily removable base rails provide a solid foundation for the entire unit and protects the unit during shipment. The rails provide fork lift access from all sides, and rigging holes are also provided so that an overhead crane can be used to place the units on a roof. On applications where the unit is placed on a pad, the base will keep the unit off the pad to deter corrosion. On applications where height is limited, the base rails may be removed by removing 2 screws in each corner.
- **Attractive Appearance** - A single-piece top cover containing a top-discharge outdoor fan arrangement requires less square footage on installation and provides a wider variety of installations. The one-piece design adds greater water integrity. Rounded corners with water drip edges add to the attractive appearance and provide cut protection to the installer
- **Top Discharge** - The top-discharge outdoor fan does not disrupt neighboring areas or dry out vegetation surrounding the unit. The warm air from the top mounted fan is blown up and away from the structure and any landscaping.
- **Outdoor Coil Grille** - All models utilize a stamped slotted design which provides superior impact protection against small objects during transit and after installation.
- **Low Operating Sound Level** - The upward air flow carries the normal operating noise up and away from the living area. The rigid top panel effectively isolates noise. Isolator mounted compressor and the rippled fins of the outdoor coil muffle the normal fan motor and compressor operating sounds. The unique formed base pan also aids in sound attenuation with its structural design.
- **Low Maintenance** - Long life, permanently lubricated outdoor and indoor fan motor bearings need no annual maintenance, adding greater reliability to the unit. Slide-out blower assembly can be easily removed for cleaning or service.
- **Fan System** - All models operate over a wide range of design conditions with an enhanced ECM indoor fan motor. These units easily match all types of applications and provide greater on-site flexibility to match comfort requirements. The cooling speed and heating speeds are factory set at test design conditions but can be field adjusted. This allows maximum comfort capabilities.
- **Dehumidification/Humidity Switch Input** - This model unit features a built in de-humidification feature for advanced dehumidification during cooling operation. The unit indoor blower control is designed to work with a humidity control that closes when the humidity is below the set-point. The control is open when the humidity is above the set-point. This humidity control may be referred to as a humidistat or dehumidistat.

To use this feature, the control HUM STAT jumper must be set to YES and a humidistat is connected from the low voltage R and HUM color coded leads. During cooling operation if the humidity level is above the humidistat set point, the indoor blower speed is reduced by approximately 15%.
- **Simple Control Circuit** - An indoor enhanced ECM blower control board and a defrost control board each contain a status/diagnostic indicator light. Field thermostat wiring connects to color coded leads using twist on wire connections. Cooling controls use a contactor and a 2nd stage 24 VAC to 24 VDC rectifier for simple application and troubleshooting. Mate-n-lock plug connectors are used. The electrical control box is not located in the compressor compartment. The controls are mounted to allow the separate access panel to be removed for trouble shooting and maintenance without affecting the normal system operating pressures. All wiring internal to the unit is color/number coded.
- **Protected Compressor** - The compressor is internally protected against high pressure and temperature. This is accomplished by the simultaneous operation of scroll bypass and a temperature thermal overload sensor which protect the compressor if undesirable operating conditions occur.
- **Pressure Switch** - A high pressure switch is standard in all units. When abnormal conditions are sensed through the pressure switch, the unit will lock out preventing any further operation until unit is reset.
- **Loss of Charge Switch** - All models include a loss of charge switch to provide safe shutdown of compressor.
- **Exclusive Coil Design** - Grooved copper tubes and enhanced aluminum fin construction improves heat transfer for maximum efficiency and durability for long-lasting durability and efficient operation. Indoor coils will use tin-coated copper tubing with aluminum fins for effective heat transfer.
- **Electric Heat (Optional)** - All PHE models use 6HK electric heat kits, which are available in 460V/3/60 from 10 kW to 25 kW. Single point field wiring kits are available for all applications.
- **Easy Service Access** - Individual access panels are provided in access to all major components - compressors, indoor coils, blower, controls/electric heat kits, filters, etc. that makes servicing easy. Removing these panels allow easy removal of the components such as the blower assembly for maintenance and ease of troubleshooting.
- **Replacement Parts** - The installer requires no special training to replace any of the components of these units and the number of new components have been reduced to minimize the inventory of unique parts.
- **Controls** - Demand defrost curves pre-loaded into defrost control for optimized performance based on unit capacities.
- **Filter Frame Kit** - All 3 phase units include a filter frame kit which is shipped inside the unit from production. Field installation is required.
- **Filters** - All 3 phase units include an applicable number of 1" washable filters, which are shipped inside the unit from production. Field installation is required. Two filters are required for A base units. Three filters are required for B base units.

NOMENCLATURE

PHE	4	A	24	2	1	A
1	2	3	4	6	8	9
1. Model Family PHE - packaged heat pump with electric heat PCG - packaged A/C with gas heat, PHG - packaged heat pump with gas heat, PCE - packaged A/C with electric heat,				5. Gas Heating Input BTU/Hr x 1000 050 = 50,000 BTU/Hr. input, blank = electric heat		
2. Nominal Cooling Efficiency 4 = 14 SEER, 6 = 16 SEER, etc.				6. Voltage-Phase-Frequency 2 = 208/230-1-60, 3=208/230-3-60, 4 = 460-3-60		
3. Cabinet Size A = small 35 x 51, B = large 45 x 51				7. NOx Approval X = low-NOx, blank = not low-Nox		
4. Nominal Air Conditioning Cooling Capacity BTUx1000 24 = 24,000 BTU, etc.				8. Generation Level 1 = first generation		
				9. Revision Level A = original release, B = second release		
Examples: PHE6B4221A is a packaged heat pump, 16 SEER, 3-1/2 ton, large cabinet, 230 volt, single phase model, (first generation, first release).						

COMPONENT LOCATION

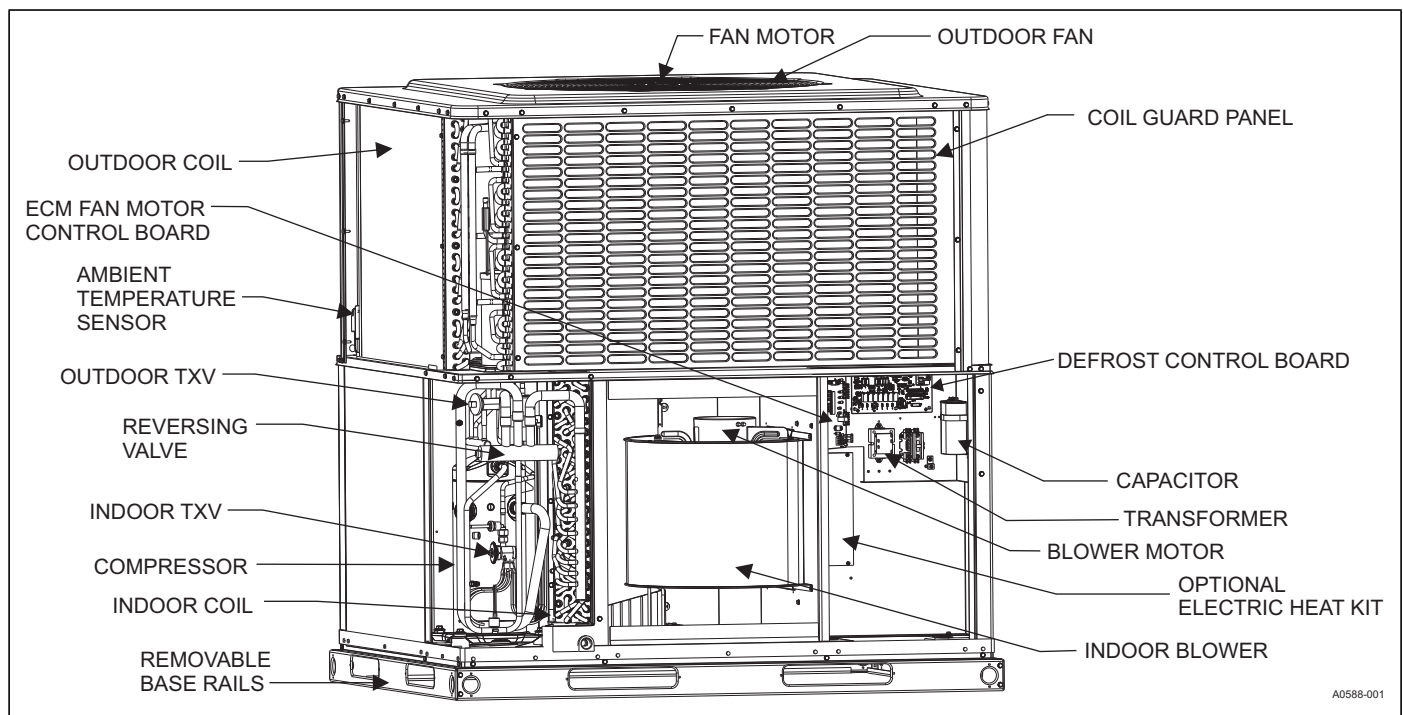

UNIT LIMITATIONS

Model	Unit Voltage	Unit Limitations		
		Applied Voltage		Outdoor DB Temp
		Min	Max	Max (°F)
PHE6B36	460-3-60	432	504	125
PHE6B48	460-3-60	432	504	125
PHE6B60	460-3-60	432	504	125

ACCESSORIES

- **Economizer for Downflow Applications (S1-2EE04710024, S1-2EE04710124)** - Modulating integrated economizer provides simultaneous operation between mechanical cooling and economizer operation. Independent blade design insures proper control and less than 1% leak rate. Includes hood and mesh bird screen filter integrated into the hood, dry bulb sensor and relief damper. Separate field accessories of single/dual enthalpy kits are also available.
- **Economizer for Horizontal Applications (S1-2EE04710224, S1-2EE04710324)** - Modulating integrated economizer provides simultaneous operation between the mechanical cooling and economizer operation. Independent blade design insures proper control and less than 1% leak rate. Includes hood and mesh bird screen filter integrated into hood, dry bulb sensor and relief damper. Separate field accessories of single enthalpy and dual enthalpy are available.
- **Single/Dual Enthalpy Sensor (S1-HE-6863-0N00WS)** - Sensor replaces supply air temperature dry bulb sensor standard in economizer kit. Provides improved economizer operation by sensing the dry bulb temperature of indoor supply air plus the enthalpy content of the indoor air.
- **Duct/Unit Mount CO2 Kit (S1-2AQ04700924)** - Sensor kit detects CO2 levels automatically and overrides the economizer when CO2 levels rise above the preset limits.
- **Wall Mount CO2 Kit (S1-2AQ04701024)** - Sensor kit detects CO2 levels automatically and overrides the economizer when CO2 levels rise above the preset limits.
- **Supply Air Temperature Sensor Kit (S1-TE-63616E-2D)** - Outdoor supply air temperature sensor kit used with economizers.
- **Filter/Frame Kit (Kit provided) (S1-1FF0602, S1-1FF0601)** - Kit contains the necessary hardware to field install return air filters into the base unit. The filter rack is suitable for either 1" or 2" filters.
- **Filter (S1-02647812000)** - Washable 1" filter. Two filters are required for A base units. Three filters are required for B base units.
- **Motorized Fresh Air Damper (S1-2MD04705224, S1-2MD04705124)** - Designed for duct mounted side supply/return and unit mounted down supply/return applications. Damper capable of providing 0% through 50% of outdoor air (field supplied). Closes on power loss, includes hood and screen assembly.
- **Rectangle to Round (Horizontal) Adapter (S1-1AK0110, S1-1AK0111)** - Kit includes one supply and one return air rectangle to round duct adapter. Adapters are preformed and designed to fit over current horizontal duct openings on the base unit. Transition is from rectangle to 12" round for the 1AK0110 kit and from rectangle to 14" round for the 1AK0111 kit.
- **Rectangle to Round (Downflow) Adapter (S1-1AK0108, S1-1AK0109)** - Kit includes one supply and one return air rectangle to round duct adapter. Adapters are preformed and designed to fit into current downflow duct openings on the roof curb. Transition is from rectangle to 16" round for the 1AK0108 kit and from rectangle to 18" round for the 1AK0109 kit.
- **Roof Curbs (S1-1RC0503, S1-1RC0501)** - NRCA approved curbs provide proper fit to base unit for rooftop installations. Curbs are designed to be assembled through hinge pins in each corner. Kit also provides seal strip to assure an air tight seal. These are 8 inch high roof curbs.
- **Roof Curbs (S1-1RC0504, S1-1RC0502)** - NRCA approved curbs provide proper fit to base unit for rooftop installations. Curbs are designed for assembly through hinge pins in each corner. Kit also provides seal strip to assure air tight seal. These are 14 inch high roof curbs.
- **Manual Outdoor Damper (S1-1FA0502, S1-1FA0501)** - Provides 0% through 50% outdoor air capability (field adjustable). Designed for duct mounted side supply/return applications and unit mounted down supply/return applications. Includes hood and screen assembly.
- **Loss of Charge Switch (S1-2LC00024)** - Kit provides Loss of Charge switch and wiring to provide safe shutdown of compressor.
- **Low Ambient Kit (S1-2LA04701024)** - Kit provides necessary hardware to convert unit to operate in cooling cycle down to 0° F. Standard unit operation 45° F.
- **Base Rail Hole Cover Kit (S1-1HC0101)** - Kit provides necessary hardware to close off openings in base rails to block off openings, i.e. prevent animal entrance.
- **Single Point Wiring Kits for 6HK Electric Heat Applications (S1-SPWK*)** - Kit provides field option for connecting electrical power supplies to the field installed 6HK heat kits and the package unit power supply to a single source of power.
- **Transition Curb Kits (S1-1TC01*)** - Adapter kits to allow field use of pre-existing installed roof curbs to match PHE6 footprint to Affinity roof curbs, Carrier, Trane, or Goodman curb footprints. Curb adapters are optional for current generation Carrier replacements but are recommended for previous generation applications. Refer to the PHE6 price pages for more details.
- **Thermostat (S1-THXU280*)** - Compatible thermostat controls are available through accessory sourcing. For optimum performance, these outdoor units are fully compatible with the York Hx™ Touchscreen Thermostat (S1-THXU280*) available through Source1. For more information, see the thermostat section of the Product Equipment Catalog.
- **Wall Thermostat** - The units are designed to operate with standard, 24-volt electronic non power stealing and electro-mechanical thermostats. All units require the use of a 3 heat / 2 cool (3H/2C) heat pump thermostat - with or without the economizer.

* For additional kit numbers refer to the price pages.

GUIDE SPECIFICATIONS

GENERAL

Units shall be manufactured by Unitary Products in an ISO 9001 certified facility. These packaged cooling/heating air conditioners are designed for outdoor installation. Only utility and duct connections are required at the point of installation. Heat pumps provide electric cooling and electric heating, with field installed electric heat kits from 10 kW to 25 kW for backup supplemental heating operation.

DESCRIPTION

Units shall be factory-assembled, single packaged, Heat Pumps with Electric Cooling/Electric Heating units, designed for outdoor installation. They shall have built in, equal size, field convertible duct connections for downflow supply/return or horizontal supply/return. The units shall be factory wired, piped, and charged with R-410A Refrigerant and factory tested prior to shipment. All models shall be rated in accordance with DOE and AHRI test procedures for both heating and cooling operation. Units shall be CSA listed to the UL 1995/CAN/CSA No. 236-M90 standards.

- **Operating Efficiency** - All heat pump models shall be rated at a minimum of 16.0 SEER, 12.5 EER and 8.2 HSPF for cooling and heating operation.
- **Low Operating Sound Level** - The upward air flow carries the normal operating noise up and away from the living area. The rigid top panel effectively isolates noise. Isolator mounted compressor and the rippled fins of the outdoor coil muffle the normal fan motor and compressor operating sounds. The unique formed base pan also aids in sound attenuation with its structural design. Sound ratings as tested under AHRI test procedures shall be less than 77 dbA for all models.

UNIT CABINET

Unit cabinet shall be a single piece design, with drip edges and no-seam corners to provide optimum water integrity. Unit shall have a rigidly mounted outdoor coil guard to provide protection from objects and personnel after installation. Indoor blower section shall be insulated with foil-faced or foam insulation, fastened to prevent insulation from entering the air stream. Cabinet panels shall be separate, easily removable for servicing and maintenance. Unit shall be built on a formed, design base pan, with embossments at critical points to add strength and rigidity and to aid in minimizing sound. Full perimeter base rails shall be provided to assure reliable transit of equipment, overhead rigging, for fork truck access and proper sealing on roof curb applications. Base rails shall be easily removable, when required to lower unit height. Filters shall be field installed, furnished and be accessible through a removable access door, sealed airtight. Units vertical discharge and return duct configuration shall be designed to fit between standard 24" O.C. beams without modification to building structure, duct work and base unit.

- **On Site Flexibility** - All model sizes shall use a compact design cabinet in one of two footprints. This provides installer flexibility for placing the proper capacity unit on curbs or pads with the smallest footprint after the internal load has been determined. Field convertible duct connections from side shot to down shot allows the installer to have greater flexibility with less inventory.

- **Durable Finish** - The cabinet shall be is made of G90 galvanized steel with a powder paint coating for appearance and protection. The pre-treated galvanized steel shall provide a better paint-to-steel bond, which resists corrosion and rust creep. Powder paint finish insure less fading when exposed to sunlight, and provides superior corrosion resistance (1000 hour salt spray tested).
- **Attractive Appearance** - A single-piece top cover containing a top-discharge outdoor fan arrangement shall be used which requires less square footage on installation and provides a wider variety of installations. The one-piece design adds greater water integrity. Rounded corners with water drip edges add to the attractive appearance and prevent water penetration.
- **Convertible Airflow Design** - The bottom duct openings are covered when they leave the factory, ready to be used for a side supply/side return application. If a bottom supply/bottom return application is desired, simply remove the two panels from the bottom of the unit and place them in the side supply/side return duct openings. No panel cutting is required and no accessory panel is necessary. Convertible airflow design allows maximum field flexibility and minimum inventory.
- **Utility Connections Made Easy** - Electric utility access shall be provided through the bottom or the side of the unit. Utility connections should be made quickly and with a minimum amount of field labor. A field supplied and field installed electrical disconnect switch must be installed.
- **Easy Service Access** - Individual access panels are provided in access to all major components - compressors, indoor coils, blower, controls/electric heat kits, filters, etc. that makes servicing easy. Removing these panels allow easy removal of the components such as the blower assembly for maintenance and ease of troubleshooting.
- **Top Discharge** - The top-discharge outdoor fan does not disrupt neighboring areas or dry out vegetation surrounding the unit. The warm air from the top mounted fan is blown up and away from the structure and any landscaping.
- **Outdoor Coil Grille** - All models utilize a stamped slotted design which provides superior impact protection against small objects during transit and after installation.

Indoor Blower Assembly - Blower shall be direct drive design. Blower wheel shall be double-inlet type with forward-curved blades, dynamically balanced to operate smoothly throughout the entire range of operation. Design shall use constant torque motors. Bearings shall be sealed and permanently lubricated for longer life and no maintenance. Fan assembly shall be a slide-out design for easy removal and cleaning. Indoor blower motors shall be equipped with a standard high efficiency brushless DC motor (constant torque) also known as an enhanced ECM motor.

Outdoor Fan Assembly - The outdoor fan shall be of the direct-driven propeller type, discharge air vertically, have aluminum blades riveted to corrosion resistant steel spider bracket and shall be statically balanced for smooth operation. The outdoor fan motor shall be totally enclosed with permanently lubricated ball bearings and internally protected against overload conditions.

REFRIGERANT COMPONENTS

- **Protected Compressor** - The compressor shall be a fully hermetic type, direct drive compressor, that is internally protected against high pressure and temperature. This is accomplished by the simultaneous operation of operation of scroll bypass and a temperature thermal overload sensor which protect the compressor if undesirable operating conditions occur. The hermetic motor shall be suction gas cooled and have a voltage range of +/- 10% of the unit nameplate voltage. Compressors shall have internal isolation and sound muffling to minimize vibration and noise, and be externally isolated on a dedicated, independent mounting.
- **Indoor Coils** - Indoor coils shall be of the direct expansion, draw through design and have aluminum plate fins mechanically bonded to seamless internally enhanced tin-coated copper tubes with all joints brazed.
- **Condensate Pan** - A corrosion-resistant, long-lasting, water-tight pan is positioned below the indoor coil to collect and drain all condensate, preventing build-up of stagnant condensate. The condensate pan conforms to ASHRAE 62-89 standards (Ventilation for Acceptable Indoor Air Quality).
- **Condensate Drain** - The 3/4 inch NPT female connection is rigidly mounted to assure proper fit and leak tight seal.
- **Outdoor Coils** - Outdoor coils shall have aluminum plate fins mechanically bonded to seamless internally enhanced copper tubes with all joints brazed, and be a draw through design.
- **Refrigerant Circuit and Refrigerant Safety Components shall include:** Thermal expansion devices (TXV's) shall be factory mounted and provided, Filter/strainer to eliminate any foreign matter, reversing valves to control refrigerant flow.

CONTROLS

- **Simple Control Circuit** - An indoor enhanced ECM blower control board and a defrost control board each contain a status/diagnostic indicator light. Field thermostat wiring connects to color coded leads using twist on wire connections. Cooling controls use a contactor and a 2nd stage 24 VAC to 24 VDC rectifier for simple application and troubleshooting. Mate-n-lock plug connectors are used. The electrical control box is not located in the compressor compartment. The controls are mounted to allow the separate access panel to be removed for trouble shooting and maintenance without affecting the normal system operating pressures. All wiring internal to the unit is color/number coded.
- **Controls** - Demand defrost curves pre-loaded into defrost control for optimized performance based on unit capacities.
- **Pressure Switch** - A high pressure switch is standard in all units. When abnormal conditions are sensed through the pressure switch, the unit will lock out preventing any further operation until unit is reset.
- **Loss of Charge Switch** - A loss of charge switch is standard in all units. When excessive compressor discharge temperatures are sensed, the unit locks out preventing any further operation until unit is reset.
- **Factory Testing** - Installation time and costs are reduced by easy power and control wiring connections. All units are completely wired, charged with refrigerant R-410A refrigerant and tested prior to shipment. Test stations using a state-of-the-art computerized process system shall be used to insure product quality. Refrigerant charge and component part numbers are verified via computer bar code scans during assembly. Vital run test statistics such as system pressure, motor currents, air velocity and temperature, unit vibration, and gas system safeties are monitored and recorded by the system to insure unit performance. This data could be provided by serial number tracking if necessary.
- **Electric Heat (Optional)** - All PHE models use 6HK electric heat kits, which are available in 460V/3/60 from 10 kW to 25kW. Single point field wiring kits are available for all applications. Electric heat kits must be certified to UL 1995 standard requirements.

PHYSICAL DATA

MODELS:	PHE6B36	PHE6B48	PHE6B60
NOMINAL TONNAGE:	3.0	4.0	5.0
COMPONENT			
AHRI Cooling Performance			
Gross Capacity @ AHRI A point (MBH)	37.0	49.1	59.2
AHRI net capacity (MBH)	36.4	47.5	57.5
EER	12.5	12.5	12.5
SEER	16.0	16.0	16.0
Nominal CFM	1200	1600	1800
System power (KW)	2.8	3.7	4.5
Refrigerant type	R410A	R410A	R410A
Refrigerant charge (lb-oz)	12-12	15-0	15-8
AHRI Heating Performance			
47 Capacity Rating (MBH)	33.3	47.4	57.2
System Power (kW/COP)	3.6	3.6	3.6
17 F Capacity Rating (MBH)	19.0	28.0	32.5
HSPF (BTU/Watts-hr.)	8.2	8.2	8.2
Dimensions (inches)			
Length	51-1/4	51-1/4	51-1/4
Width	45-3/4	45-3/4	45-3/4
Height	49	53	55
Operating WT. (lbs.)	448	496	523
Compressors			
Type	Scroll	Scroll	Scroll
Stages	2	2	2
Outdoor Coil Data			
Face area (Sq. Ft.)	19.5	23.8	25.9
Rows	2	2	2
Fins per inch	22	22	22
Tube diameter	3/8	3/8	3/8
Circuitry Type	Interlaced	Interlaced	Interlaced
Refrigerant control	TXV	TXV	TXV
Indoor Coil Data			
Face area (Sq. Ft.)	6.3	6.3	6.3
Rows	3	3	4
Fins per inch	16	16	16
Tube diameter	3/8	3/8	3/8
Circuitry Type	Interlaced	Interlaced	Interlaced
Refrigerant control	TXV	TXV	TXV
Outdoor Fan Data			
Fan diameter (Inch)	26	26	26
Type	Prop	Prop	Prop
Drive type	Direct	Direct	Direct
No. speeds	1	1	1
Motor HP each	1/3	1/3	1/3
RPM	850	850	850
Nominal total CFM	4000	4200	4200
Direct Drive Indoor Blower Data			
Fan Size (Inch)	11 x 10	11 x 10	11 x 10
Type	Centrifugal	Centrifugal	Centrifugal
Motor HP each	1/2	1	1
RPM	1200 Max	1200 Max	1200 Max
Frame size	48	48	48
Filters			
Filter size	B	B	B
Quantity - Size	Field-supplied external filters must be sized so as not to exceed 300 fpm air velocity through disposable filters. For internal filter use, a filter rack kit is available. Consult the instructions supplied with that kit for replacement filter sizes. Filter sizes: A=20x10 (2 each), B=20x10 (3 each).		

COOLING PERFORMANCE DATA - 3 TON (LOW SPEED)																
PACKAGED UNIT MODEL NO. PHE6B36																
CONDENSER ENTERING AIR TEMPERATURE	ID CFM	600					800					1000				
		IDDB	80	80	75	80	80	80	80	80	80	80	80	80	80	80
		IDWB	57	62	62	67	72	57	62	62	67	72	57	62	62	67
55 / 45	T.C.	25.7	28.0	28.1	31.4	33.6	29.0	30.2	30.5	33.9	36.3	32.3	32.4	33.0	36.3	39.0
	S.C.	24.3	21.9	19.0	19.0	15.6	27.6	25.8	21.8	21.8	17.4	30.9	29.7	24.7	24.6	19.1
	K.W.	1.12	1.10	1.11	1.08	1.06	1.05	1.04	1.05	1.02	1.01	0.99	0.99	1.00	0.97	0.96
65 / 55	T.C.	24.2	26.2	26.7	29.4	32.6	27.0	28.5	28.9	32.0	35.1	29.8	30.8	31.2	34.7	37.5
	S.C.	23.3	21.0	18.1	18.1	14.8	26.2	25.1	21.1	21.1	16.7	29.1	29.2	24.0	24.0	18.6
	K.W.	1.28	1.26	1.26	1.24	1.21	1.21	1.20	1.20	1.18	1.16	1.15	1.14	1.15	1.13	1.11
75 / 63	T.C.	22.6	24.5	25.3	27.5	31.7	25.0	26.8	27.3	30.2	33.9	27.3	29.2	29.3	33.0	36.0
	S.C.	22.3	20.2	17.3	17.3	14.1	24.8	24.4	20.3	20.4	16.1	27.3	28.7	23.3	23.4	18.1
	K.W.	1.44	1.41	1.41	1.39	1.36	1.37	1.36	1.36	1.34	1.31	1.31	1.30	1.30	1.28	1.26
85 / 69	T.C.	21.2	22.9	23.4	26.0	30.1	23.5	25.0	25.3	28.4	31.9	25.8	27.0	27.2	30.7	33.8
	S.C.	21.0	19.3	16.4	16.5	13.4	23.4	23.0	19.4	19.5	15.3	25.8	26.8	22.3	22.6	17.2
	K.W.	1.64	1.63	1.62	1.60	1.57	1.58	1.57	1.56	1.54	1.52	1.51	1.51	1.51	1.49	1.46
95 / 75	T.C.	19.7	21.3	21.6	24.6	28.5	22.0	23.1	23.3	26.5	30.0	24.3	24.9	25.1	28.5	31.6
	S.C.	19.7	18.5	15.5	15.7	12.8	22.0	21.6	18.4	18.7	14.5	24.3	24.8	21.3	21.7	16.3
	K.W.	1.85	1.84	1.83	1.80	1.77	1.78	1.78	1.77	1.75	1.72	1.72	1.72	1.72	1.70	1.66
105 / 83	T.C.	17.5	19.3	19.2	22.1	25.7	19.5	20.8	20.7	23.7	27.2	21.4	22.4	22.3	25.3	28.7
	S.C.	17.5	17.1	14.3	14.6	11.7	19.5	19.7	17.0	17.4	13.4	21.4	22.4	19.7	20.2	15.1
	K.W.	2.13	2.12	2.12	2.09	2.07	2.07	2.06	2.06	2.04	2.01	2.00	2.00	2.01	1.99	1.96
115 / 89	T.C.	15.5	17.3	16.9	19.8	23.0	17.0	18.6	18.2	21.0	24.5	18.6	19.9	19.5	22.2	25.9
	S.C.	15.5	15.9	13.1	13.5	10.7	17.0	17.9	15.6	16.1	12.3	18.5	19.9	18.2	18.8	13.9
	K.W.	2.40	2.39	2.40	2.38	2.35	2.34	2.34	2.35	2.33	2.30	2.28	2.28	2.30	2.27	2.24
125 / 95	T.C.	13.4	15.3	14.6	17.4	20.3	14.5	16.4	15.7	18.3	21.7	15.7	17.5	16.8	19.1	23.1
	S.C.	13.4	14.6	12.0	12.4	9.6	14.5	16.1	14.3	14.9	11.2	15.7	17.5	16.6	17.4	12.8
	K.W.	2.68	2.67	2.68	2.66	2.64	2.62	2.61	2.63	2.61	2.58	2.56	2.56	2.58	2.56	2.53

COOLING PERFORMANCE DATA - 3 TON (HIGH SPEED)																
PACKAGED UNIT MODEL NO. PHE6B36																
CONDENSER ENTERING AIR TEMPERATURE	ID CFM	1000					1200					1400				
		IDDB	80	80	75	80	80	80	80	75	80	80	80	80	75	80
		IDWB	57	62	62	67	72	57	62	62	67	72	57	62	62	67
55 / 45	T.C.	38.4	40.9	39.9	43.0	46.5	41.0	42.7	41.6	45.5	48.3	43.7	44.4	43.4	47.9	50.1
	S.C.	35.6	32.0	27.1	27.4	0.6	37.9	35.1	29.6	29.5	12.7	40.1	38.3	32.1	31.6	24.7
	K.W.	1.83	1.86	1.85	1.88	1.90	1.92	1.93	1.92	1.96	1.97	2.00	2.00	2.00	2.03	2.05
65 / 55	T.C.	37.0	38.6	31.9	41.5	44.1	39.5	40.3	36.5	43.4	46.5	42.0	42.1	41.1	45.4	48.8
	S.C.	34.2	31.1	25.3	26.4	11.4	36.4	34.3	28.3	28.7	17.6	38.5	37.5	31.3	31.0	23.9
	K.W.	2.01	2.03	2.80	2.06	2.08	2.10	2.11	2.49	2.14	2.16	2.19	2.19	2.18	2.22	2.23
75 / 63	T.C.	35.5	36.2	24.0	40.0	41.8	37.9	38.0	31.4	41.4	44.6	40.3	39.7	38.8	42.9	47.4
	S.C.	32.9	30.2	23.4	25.4	22.2	34.9	33.5	27.0	27.9	22.6	36.9	36.8	30.6	30.4	23.0
	K.W.	2.19	2.21	3.75	2.24	2.25	2.28	2.29	3.05	2.32	2.34	2.37	2.37	2.36	2.40	2.42
85 / 69	T.C.	33.8	34.0	27.8	37.3	40.2	36.0	35.5	32.0	38.7	42.5	38.2	37.0	36.2	40.0	44.7
	S.C.	31.2	29.0	23.2	24.3	20.3	33.0	32.1	26.2	26.7	21.1	34.9	35.3	29.2	29.1	21.9
	K.W.	2.43	2.45	3.22	2.48	2.49	2.52	2.53	2.91	2.56	2.57	2.60	2.60	2.59	2.63	2.65
95 / 75	T.C.	32.1	31.8	31.6	34.7	38.6	34.1	33.0	32.6	35.9	40.3	36.1	34.2	33.6	37.1	42.0
	S.C.	29.5	27.9	23.0	23.2	18.3	31.2	30.8	25.4	25.5	19.6	32.9	33.7	27.7	27.8	20.8
	K.W.	2.67	2.68	2.68	2.72	2.73	2.76	2.76	2.76	2.79	2.81	2.84	2.84	2.83	2.86	2.88
105 / 83	T.C.	29.3	28.9	28.7	31.5	35.6	31.0	30.0	29.4	32.4	36.9	32.6	31.1	30.1	33.4	38.2
	S.C.	27.4	26.2	21.5	21.7	16.9	28.9	28.4	23.7	24.0	18.1	30.3	30.6	26.0	26.3	19.3
	K.W.	3.04	3.04	3.04	3.07	3.09	3.12	3.12	3.11	3.14	3.16	3.20	3.20	3.19	3.21	3.24
115 / 89	T.C.	26.7	26.1	25.9	28.4	32.7	27.9	27.0	26.3	29.0	33.6	29.2	28.0	26.7	29.7	34.5
	S.C.	25.4	24.5	20.1	20.3	15.6	26.6	26.0	22.2	22.6	16.7	27.8	27.6	24.3	24.9	17.9
	K.W.	3.39	3.39	3.39	3.42	3.43	3.47	3.47	3.46	3.49	3.51	3.55	3.55	3.53	3.56	3.58
125 / 95	T.C.	24.0	23.2	23.0	25.3	29.8	24.9	24.1	23.2	25.7	30.3	25.8	24.9	23.4	26.1	30.8
	S.C.	23.4	22.9	18.7	18.9	14.3	24.4	23.7	20.6	21.1	15.3	25.4	24.5	22.5	23.4	16.4
	K.W.	3.75	3.74	3.74	3.76	3.78	3.82	3.82	3.81	3.83	3.85	3.90	3.90	3.87	3.90	3.92

COOLING PERFORMANCE DATA - 4 TON (LOW SPEED)																	
PACKAGED UNIT MODEL NO. PHE6B48																	
CONDENSER ENTERING AIR TEMPERATURE	ID CFM	1050					1250					1450					
		IDDB	80	80	75	80	80	80	80	75	80	80	80	80	75	80	80
		IDWB	57	62	62	67	72	57	62	62	67	72	57	62	62	67	72
55 / 45	T.C.	38.0	38.6	42.2	45.8	48.4	39.5	40.2	43.4	47.0	49.8	40.9	41.7	44.6	48.2	51.2	
	S.C.	38.0	34.4	29.9	29.6	23.7	39.5	37.8	32.4	31.9	25.2	40.9	41.2	34.9	34.3	26.7	
	K.W.	1.63	1.61	1.62	1.60	1.57	1.59	1.57	1.59	1.56	1.54	1.55	1.53	1.56	1.52	1.51	
65 / 55	T.C.	35.9	36.9	39.4	43.5	47.1	37.3	37.9	40.8	44.6	48.2	38.6	38.9	42.1	45.7	49.3	
	S.C.	35.9	33.2	28.4	28.4	22.7	37.3	35.9	31.0	30.9	24.3	38.6	38.6	33.5	33.4	25.9	
	K.W.	1.90	1.88	1.88	1.86	1.82	1.85	1.84	1.85	1.82	1.79	1.81	1.80	1.81	1.78	1.76	
75 / 63	T.C.	33.9	35.2	36.6	41.2	45.8	35.0	35.6	38.2	42.2	46.6	36.2	36.0	39.7	43.3	47.4	
	S.C.	33.9	32.0	26.8	27.2	21.6	35.0	34.0	29.5	29.9	23.3	36.2	36.0	32.2	32.6	25.0	
	K.W.	2.17	2.14	2.14	2.12	2.07	2.12	2.11	2.11	2.08	2.04	2.07	2.07	2.07	2.05	2.01	
85 / 69	T.C.	31.9	31.9	33.5	37.8	41.2	33.0	32.5	34.7	38.7	42.2	34.1	33.1	35.8	39.6	43.1	
	S.C.	31.9	30.2	25.3	25.8	20.4	33.0	31.7	27.7	28.4	21.8	34.1	33.1	30.2	30.9	23.3	
	K.W.	2.50	2.49	2.49	2.46	2.42	2.46	2.45	2.45	2.43	2.38	2.41	2.41	2.42	2.39	2.35	
95 / 75	T.C.	30.0	28.7	30.4	34.5	36.6	31.0	29.4	31.2	35.2	37.7	32.0	30.2	32.0	35.9	38.8	
	S.C.	30.0	28.5	23.7	24.4	19.1	31.0	29.3	26.0	26.8	20.3	32.0	30.2	28.3	29.2	21.6	
	K.W.	2.84	2.83	2.84	2.80	2.77	2.79	2.79	2.80	2.77	2.73	2.75	2.75	2.76	2.74	2.69	
105 / 83	T.C.	27.8	25.0	26.6	30.1	32.9	28.6	26.2	27.1	30.9	33.6	29.4	27.5	27.5	31.6	34.3	
	S.C.	27.3	24.9	21.1	22.3	16.9	28.3	26.2	23.1	24.8	18.3	29.4	27.5	25.1	27.2	19.7	
	K.W.	3.29	3.28	3.28	3.26	3.22	3.24	3.24	3.26	3.22	3.18	3.20	3.20	3.23	3.19	3.15	
115 / 89	T.C.	25.7	21.4	23.0	25.9	29.3	26.3	23.1	23.1	26.7	29.6	26.9	24.8	23.2	27.5	29.8	
	S.C.	24.7	21.4	18.6	20.4	14.8	25.8	23.1	20.3	22.8	16.3	26.9	24.8	22.0	25.3	17.8	
	K.W.	3.73	3.72	3.72	3.71	3.65	3.68	3.68	3.70	3.67	3.62	3.63	3.64	3.68	3.63	3.59	
125 / 95	T.C.	23.6	17.9	19.3	21.7	25.7	24.0	20.0	19.1	22.5	25.6	24.4	22.1	18.8	23.3	25.4	
	S.C.	22.0	17.9	16.0	18.4	12.7	23.2	20.0	17.4	20.8	14.3	24.4	22.1	18.8	23.3	16.0	
	K.W.	4.16	4.16	4.15	4.15	4.09	4.11	4.12	4.14	4.11	4.07	4.06	4.08	4.12	4.06	4.04	

COOLING PERFORMANCE DATA - 4 TON (HIGH SPEED)																
PACKAGED UNIT MODEL NO. PHE6B48																
CONDENSER ENTERING AIR TEMPERATURE	ID CFM	1350					1550					1750				
		IDDB	80	80	75	80	80	80	75	80	80	80	80	75	80	80
		IDWB	57	62	62	67	72	57	62	62	67	72	57	62	62	67
55 / 45	T.C.	50.4	51.0	53.4	58.8	61.8	52.7	52.5	55.1	60.0	63.5	55.0	53.9	56.7	61.3	65.3
	S.C.	50.3	44.3	37.2	36.9	29.3	52.1	46.8	39.8	39.1	30.4	53.8	49.4	42.5	41.2	31.5
	K.W.	2.68	2.71	2.71	2.74	2.78	2.76	2.78	2.78	2.81	2.84	2.83	2.86	2.84	2.88	2.90
65 / 55	T.C.	45.9	47.7	48.9	55.8	59.1	47.3	49.2	50.2	57.3	61.2	48.6	50.6	51.6	58.7	63.4
	S.C.	45.9	42.7	35.9	36.0	27.9	46.9	45.4	38.2	38.0	29.2	48.0	48.1	40.6	40.0	30.5
	K.W.	2.96	2.99	2.98	3.03	3.06	3.04	3.06	3.05	3.10	3.13	3.11	3.14	3.12	3.16	3.20
75 / 63	T.C.	41.4	44.4	44.3	52.8	56.4	41.8	45.9	45.4	54.5	59.0	42.2	47.3	46.4	56.2	61.5
	S.C.	41.4	41.0	34.5	35.1	26.5	41.8	43.9	36.6	36.9	28.0	42.2	46.7	38.7	38.8	29.5
	K.W.	3.24	3.27	3.26	3.31	3.35	3.32	3.34	3.32	3.38	3.42	3.39	3.41	3.39	3.45	3.50
85 / 69	T.C.	39.4	40.9	41.2	49.0	52.0	39.5	41.8	41.9	50.2	54.2	39.7	42.6	42.6	51.5	56.3
	S.C.	39.4	39.0	32.5	33.1	24.7	39.5	40.7	34.7	35.0	25.9	39.7	42.4	36.9	36.9	27.0
	K.W.	3.61	3.63	3.62	3.67	3.71	3.69	3.70	3.69	3.74	3.79	3.76	3.77	3.75	3.81	3.86
95 / 75	T.C.	37.3	37.5	38.1	45.3	47.6	37.2	37.7	38.4	46.0	49.4	37.2	38.0	38.8	46.7	51.2
	S.C.	37.3	37.0	30.4	31.1	23.0	37.2	37.5	32.8	33.1	23.8	37.2	38.0	35.1	35.1	24.6
	K.W.	3.98	3.99	3.98	4.02	4.08	4.05	4.05	4.05	4.09	4.15	4.13	4.12	4.12	4.16	4.22
105 / 83	T.C.	34.4	33.7	33.7	40.9	43.4	34.4	34.2	33.7	41.5	44.5	34.4	34.8	33.7	42.1	45.7
	S.C.	34.4	33.3	28.0	29.2	21.3	34.4	34.1	29.6	31.2	22.0	34.4	34.8	31.3	33.2	22.7
	K.W.	4.52	4.53	4.51	4.56	4.60	4.59	4.59	4.58	4.62	4.67	4.66	4.65	4.65	4.69	4.74
115 / 89	T.C.	31.6	30.0	29.4	36.6	39.2	31.6	30.8	29.0	37.1	39.8	31.6	31.6	28.7	37.6	40.3
	S.C.	31.6	29.8	25.6	27.4	19.6	31.6	30.7	26.6	29.4	20.3	31.6	31.6	27.5	31.4	20.9
	K.W.	5.05	5.04	5.03	5.08	5.10	5.11	5.11	5.10	5.14	5.17	5.18	5.17	5.16	5.20	5.24
125 / 95	T.C.	28.8	26.3	25.1	32.4	35.1	28.9	27.4	24.4	32.8	35.1	28.9	28.5	23.8	33.1	35.0
	S.C.	28.8	26.3	23.2	25.6	17.9	28.9	27.4	23.5	27.5	18.5	28.9	28.5	23.8	29.5	19.2
	K.W.	5.57	5.56	5.55	5.61	5.61	5.64	5.62	5.61	5.66	5.68	5.70	5.69	5.67	5.71	5.75

COOLING PERFORMANCE DATA - 5 TON (LOW SPEED)																	
PACKAGED UNIT MODEL NO. PHE6B60																	
CONDENSER ENTERING AIR TEMPERATURE	ID CFM	1150					1350					1550					
		IDDB	80	80	75	80	80	80	80	75	80	80	80	80	75	80	80
		IDWB	57	62	62	67	72	57	62	62	67	72	57	62	62	67	72
55 / 45	T.C.	46.1	50.2	50.9	56.9	63.1	47.6	51.3	51.1	58.1	63.4	49.1	52.5	51.3	59.3	63.7	
	S.C.	44.9	40.0	34.8	34.4	28.8	46.9	42.9	36.9	36.6	29.6	49.0	45.8	39.1	38.8	30.4	
	K.W.	2.03	1.99	2.01	1.98	1.94	2.03	2.00	2.01	1.98	1.95	2.03	2.01	2.01	1.99	1.95	
65 / 55	T.C.	43.7	46.8	47.0	52.6	58.8	45.3	47.8	47.4	53.7	58.9	46.8	48.8	47.9	54.9	59.1	
	S.C.	42.7	38.3	33.0	32.7	27.2	44.5	41.0	35.0	34.9	28.3	46.4	43.6	37.0	37.2	29.4	
	K.W.	2.34	2.29	2.30	2.27	2.22	2.34	2.29	2.29	2.27	2.23	2.33	2.30	2.29	2.28	2.23	
75 / 63	T.C.	41.3	43.4	43.1	48.2	54.5	42.9	44.2	43.7	49.3	54.5	44.5	45.0	44.4	50.5	54.5	
	S.C.	40.4	36.6	31.2	30.9	25.7	42.1	39.0	33.1	33.3	27.0	43.7	41.5	34.9	35.6	28.4	
	K.W.	2.65	2.58	2.58	2.56	2.50	2.64	2.58	2.58	2.57	2.50	2.63	2.58	2.57	2.57	2.50	
85 / 69	T.C.	38.8	39.7	39.2	44.8	50.4	40.4	40.3	39.7	45.5	50.6	42.0	40.9	40.2	46.3	50.7	
	S.C.	38.0	34.3	29.2	29.5	23.8	39.3	36.6	30.9	31.6	25.0	40.7	38.8	32.6	33.7	26.2	
	K.W.	3.02	2.95	2.95	2.93	2.88	3.01	2.95	2.95	2.94	2.88	3.00	2.96	2.96	2.95	2.88	
95 / 75	T.C.	36.3	36.0	35.4	41.3	46.4	37.9	36.4	35.7	41.7	46.7	39.5	36.8	36.0	42.1	47.0	
	S.C.	35.5	32.0	27.2	28.0	21.9	36.6	34.1	28.8	29.9	23.0	37.7	36.2	30.3	31.8	24.0	
	K.W.	3.39	3.32	3.32	3.30	3.25	3.38	3.33	3.33	3.31	3.26	3.37	3.33	3.34	3.32	3.26	
105 / 83	T.C.	33.0	32.3	31.3	36.6	41.3	34.1	32.5	31.3	36.8	41.3	35.3	32.7	31.4	36.9	41.3	
	S.C.	32.4	29.7	25.0	25.9	19.8	33.2	31.0	26.4	27.6	20.8	34.1	32.3	27.7	29.4	21.8	
	K.W.	3.87	3.81	3.82	3.79	3.75	3.86	3.82	3.83	3.80	3.75	3.85	3.82	3.83	3.81	3.76	
115 / 89	T.C.	29.7	28.8	27.3	32.1	36.5	30.5	28.8	27.2	32.0	36.1	31.2	28.7	27.0	31.9	35.7	
	S.C.	29.4	27.4	22.9	23.8	17.9	30.0	28.0	24.0	25.4	18.8	30.6	28.5	25.1	27.0	19.7	
	K.W.	4.33	4.29	4.30	4.27	4.22	4.32	4.29	4.30	4.27	4.23	4.31	4.29	4.31	4.28	4.24	
125 / 95	T.C.	26.4	25.2	23.3	27.6	31.6	26.8	25.0	23.0	27.2	30.9	27.2	24.8	22.6	26.9	30.2	
	S.C.	26.4	25.2	20.7	21.8	15.9	26.7	24.9	21.6	23.2	16.7	27.1	24.7	22.6	24.6	17.6	
	K.W.	4.79	4.77	4.78	4.74	4.70	4.78	4.77	4.78	4.75	4.71	4.78	4.77	4.79	4.75	4.72	

COOLING PERFORMANCE DATA - 5 TON (HIGH SPEED)																	
PACKAGED UNIT MODEL NO. PHE6B60																	
CONDENSER ENTERING AIR TEMPERATURE	ID CFM	1600					1800					2000					
		IDDB	80	80	75	80	80	80	80	75	80	80	80	80	75	80	80
		IDWB	57	62	62	67	72	57	62	62	67	72	57	62	62	67	72
55 / 45	T.C.	60.7	66.7	64.3	72.7	76.9	62.6	67.7	65.8	73.8	77.1	64.5	68.7	67.4	74.9	77.2	
	S.C.	60.3	52.5	45.5	45.9	38.6	62.4	55.4	47.5	47.7	39.3	64.4	58.3	49.5	49.6	40.1	
	K.W.	3.19	3.26	3.58	3.36	3.71	3.46	3.52	3.67	3.61	3.78	3.72	3.77	3.77	3.86	3.86	
65 / 55	T.C.	57.4	62.5	61.2	68.2	73.2	59.2	63.6	62.2	68.7	73.4	61.0	64.6	63.1	69.1	73.5	
	S.C.	57.2	50.6	43.3	44.0	36.8	59.1	53.4	45.4	45.8	37.6	60.9	56.2	47.6	47.6	38.5	
	K.W.	3.68	3.75	3.75	3.68	4.04	3.87	3.92	3.92	3.93	4.13	4.05	4.10	4.09	4.18	4.21	
75 / 63	T.C.	54.1	58.4	58.2	63.8	69.6	55.8	59.5	58.5	63.5	69.7	57.5	60.5	58.9	63.2	69.9	
	S.C.	54.1	48.7	41.1	42.0	35.0	55.8	51.4	43.4	43.8	35.9	57.4	54.1	45.7	45.6	36.8	
	K.W.	4.17	4.24	3.92	4.00	4.37	4.28	4.33	4.16	4.25	4.47	4.38	4.42	4.41	4.51	4.56	
85 / 69	T.C.	50.5	54.3	53.1	59.5	64.2	51.6	54.9	53.5	59.2	64.7	52.7	55.6	53.9	59.0	65.2	
	S.C.	50.5	46.4	39.0	39.9	32.3	51.6	48.8	41.0	41.4	32.9	52.7	51.1	42.9	43.0	33.5	
	K.W.	4.45	4.66	4.50	4.43	4.81	4.63	4.76	4.67	4.68	4.90	4.82	4.85	4.83	4.93	5.00	
95 / 75	T.C.	47.0	50.2	48.1	55.1	58.8	47.5	50.4	48.5	54.9	59.6	48.0	50.7	48.8	54.7	60.5	
	S.C.	46.9	44.0	37.0	37.8	29.6	47.4	46.1	38.6	39.1	29.9	48.0	48.1	40.2	40.4	30.2	
	K.W.	4.72	5.09	5.09	4.85	5.25	4.99	5.18	5.17	5.10	5.34	5.25	5.27	5.25	5.35	5.43	
105 / 83	T.C.	42.3	45.1	43.6	49.1	53.1	43.1	45.2	43.5	48.7	53.3	43.9	45.3	43.3	48.2	53.6	
	S.C.	42.3	41.0	34.3	35.1	26.9	43.1	42.3	35.8	36.5	27.3	43.9	43.6	37.3	37.9	27.8	
	K.W.	5.47	5.71	5.60	5.46	5.74	5.67	5.80	5.74	5.70	5.88	5.88	5.89	5.87	5.95	6.03	
115 / 89	T.C.	37.8	40.1	39.3	43.3	47.5	38.9	40.1	38.6	42.6	47.2	40.0	40.1	38.0	42.0	46.9	
	S.C.	37.7	38.0	31.7	32.5	24.3	38.8	38.6	33.1	34.0	24.9	39.9	39.2	34.5	35.4	25.4	
	K.W.	6.19	6.32	6.10	6.04	6.22	6.34	6.41	6.29	6.29	6.41	6.48	6.50	6.48	6.53	6.61	
125 / 95	T.C.	33.2	35.1	35.0	37.5	42.0	34.6	35.0	33.8	36.6	41.1	36.0	34.8	32.6	35.7	40.2	
	S.C.	33.2	35.0	29.1	29.9	21.7	34.6	34.9	30.4	31.4	22.4	36.0	34.8	31.7	33.0	23.0	
	K.W.	6.91	6.92	6.59	6.63	6.70	7.00	7.02	6.84	6.87	6.94	7.09	7.11	7.08	7.11	7.18	

HEATING PERFORMANCE DATA - 3.0 TON (LOW SPEED)										
PACKAGED UNIT MODEL NO. PHE6B36										
AIR TEMPERATURE ENTERING OUTDOOR UNIT	AIR TEMPERATURE ENTERING INDOOR COIL	ID CFM								
		600			800			1000		
		MBH	COP	KW	MBH	COP	KW	MBH	COP	KW
60	60	30.3	5.01	1.72	29.4	4.36	1.89	28.4	3.84	2.07
	70	29.0	4.28	1.93	28.0	3.74	2.12	27.0	3.29	2.31
	80	27.8	3.69	2.15	26.6	3.22	2.34	25.5	2.83	2.54
47	60	25.3	4.18	1.72	24.3	3.67	1.87	23.3	3.24	2.01
	70	23.8	3.51	1.93	22.9	3.11	2.08	22.0	2.77	2.24
	80	22.2	2.96	2.14	21.5	2.65	2.30	20.8	2.38	2.47
40	60	22.0	3.63	1.72	21.2	3.22	1.85	20.4	2.88	1.99
	70	20.6	3.06	1.92	19.9	2.72	2.07	19.1	2.43	2.21
	80	19.3	2.59	2.13	18.6	2.31	2.28	17.9	2.07	2.44

HEATING PERFORMANCE DATA - 3.0 TON (HIGH SPEED)										
PACKAGED UNIT MODEL NO. PHE6B36										
AIR TEMPERATURE ENTERING OUTDOOR UNIT	AIR TEMPERATURE ENTERING INDOOR COIL	ID CFM								
		1000			1200			1400		
		MBH	COP	KW	MBH	COP	KW	MBH	COP	KW
60	60	43.9	4.52	2.53	43.0	4.45	2.58	42.0	4.37	2.64
	70	42.1	4.01	2.76	41.2	3.94	2.82	40.3	3.87	2.88
	80	40.2	3.57	2.99	39.5	3.51	3.05	38.7	3.44	3.11
47	60	36.0	3.84	2.44	35.7	3.85	2.47	35.3	3.85	2.50
	70	34.5	3.41	2.66	34.1	3.39	2.70	33.7	3.37	2.75
	80	33.1	3.04	2.88	32.5	3.00	2.93	32.0	2.96	2.99
40	60	31.9	3.45	2.40	31.4	3.45	2.42	30.9	3.45	2.45
	70	30.5	3.04	2.62	30.0	3.04	2.65	29.6	3.03	2.69
	80	29.0	2.69	2.84	28.6	2.68	2.89	28.3	2.67	2.93
30	60	26.6	2.93	2.34	26.1	2.97	2.33	25.6	3.01	2.31
	70	25.4	2.59	2.56	25.0	2.60	2.57	24.6	2.62	2.57
	80	24.2	2.29	2.78	23.9	2.29	2.81	23.6	2.29	2.83
17	60	20.0	2.26	2.27	19.7	2.30	2.26	19.4	2.33	2.25
	70	18.8	1.97	2.48	18.6	2.00	2.48	18.5	2.03	2.49
	80	17.6	1.72	2.69	17.5	1.74	2.70	17.5	1.77	2.72
10	60	15.9	1.83	2.24	16.3	1.93	2.22	16.6	2.05	2.20
	70	8.5	0.95	2.30	12.0	1.35	2.36	15.6	1.75	2.42
	80	1.1	0.12	2.38	7.8	0.83	2.50	14.5	1.51	2.64

HEATING PERFORMANCE DATA - 4.0 TON (LOW SPEED)										
PACKAGED UNIT MODEL NO. PHE6B48										
AIR TEMPERATURE ENTERING OUTDOOR UNIT	AIR TEMPERATURE ENTERING INDOOR COIL	ID CFM								
		1000			1200			1400		
		MBH	COP	KW	MBH	COP	KW	MBH	COP	KW
60	60	44.4	4.83	2.48	44.3	4.55	2.68	44.1	4.31	2.89
	70	42.2	4.08	2.80	41.9	3.82	3.05	41.7	3.59	3.29
	80	39.9	3.48	3.14	39.6	3.24	3.42	39.3	3.02	3.70
47	60	35.9	3.90	2.48	35.9	3.71	2.67	35.9	3.54	2.85
	70	33.6	3.25	2.81	33.4	3.08	3.01	33.3	2.92	3.21
	80	31.3	2.72	3.15	31.0	2.57	3.36	30.6	2.43	3.57
40	60	31.4	3.41	2.48	31.3	3.25	2.65	31.2	3.11	2.82
	70	29.3	2.87	2.78	29.3	2.73	2.98	29.3	2.61	3.17
	80	27.3	2.42	3.08	27.3	2.30	3.30	27.3	2.20	3.51

HEATING PERFORMANCE DATA - 4.0 TON (HIGH SPEED)										
PACKAGED UNIT MODEL NO. PHE6B48										
AIR TEMPERATURE ENTERING OUTDOOR UNIT	AIR TEMPERATURE ENTERING INDOOR COIL	ID CFM								
		1300			1500			1700		
		MBH	COP	KW	MBH	COP	KW	MBH	COP	KW
60	60	61.4	4.63	3.46	60.8	4.52	3.56	60.1	4.42	3.68
	70	58.7	4.04	3.82	58.2	3.93	3.97	57.7	3.82	4.12
	80	56.0	3.55	4.19	55.7	3.43	4.38	55.3	3.32	4.57
47	60	50.9	3.97	3.32	50.3	3.87	3.43	49.6	3.78	3.53
	70	48.3	3.43	3.71	48.0	3.34	3.83	47.7	3.26	3.97
	80	45.8	2.97	4.09	45.8	2.91	4.24	45.7	2.84	4.40
40	60	44.7	3.51	3.30	44.7	3.48	3.39	44.6	3.45	3.48
	70	42.6	3.02	3.70	42.6	2.99	3.81	42.7	2.95	3.92
	80	40.5	2.62	4.09	40.6	2.58	4.23	40.7	2.55	4.36
30	60	36.8	2.92	3.25	36.9	2.93	3.31	37.0	2.94	3.38
	70	35.1	2.55	3.59	35.2	2.51	3.73	35.3	2.47	3.88
	80	33.4	2.24	3.94	33.5	2.17	4.15	33.6	2.10	4.38
17	60	28.0	2.26	3.20	28.2	2.29	3.23	28.4	2.33	3.26
	70	26.3	1.94	3.55	26.6	1.94	3.64	26.9	1.95	3.73
	80	24.6	1.66	3.90	25.0	1.66	4.05	25.4	1.65	4.19
10	60	25.3	2.11	3.08	25.5	2.14	3.11	25.6	2.17	3.15
	70	23.3	1.76	3.44	23.5	1.78	3.49	23.9	1.81	3.55
	80	21.2	1.47	3.78	21.6	1.49	3.86	22.1	1.52	3.95

HEATING PERFORMANCE DATA - 5.0 TON (LOW SPEED)										
PACKAGED UNIT MODEL NO. PHE6B60										
AIR TEMPERATURE ENTERING OUTDOOR UNIT	AIR TEMPERATURE ENTERING INDOOR COIL	ID CFM								
		1030			1230			1430		
		MBH	COP	KW	MBH	COP	KW	MBH	COP	KW
60	60	53.8	4.73	2.98	54.5	4.57	3.22	55.1	4.42	3.47
	70	51.7	4.09	3.34	52.2	3.93	3.61	52.7	3.79	3.88
	80	49.6	3.57	3.72	49.9	3.42	4.01	50.2	3.28	4.30
47	60	45.2	4.06	2.91	46.3	4.03	3.09	47.3	4.01	3.27
	70	43.2	3.50	3.25	44.0	3.46	3.46	44.9	3.42	3.67
	80	41.1	3.04	3.60	41.8	2.98	3.83	42.5	2.94	4.05
40	60	40.6	3.66	2.90	41.1	3.62	3.05	41.6	3.60	3.21
	70	38.4	3.14	3.23	39.0	3.12	3.40	39.7	3.09	3.57
	80	36.3	2.72	3.55	37.0	2.70	3.75	37.7	2.68	3.94

HEATING PERFORMANCE DATA - 5.0 TON (HIGH SPEED)										
PACKAGED UNIT MODEL NO. PHE6B60										
AIR TEMPERATURE ENTERING OUTDOOR UNIT	AIR TEMPERATURE ENTERING INDOOR COIL	ID CFM								
		1530			1730			1930		
		MBH	COP	KW	MBH	COP	KW	MBH	COP	KW
60	60	73.6	4.77	4.15	73.1	4.56	4.18	72.5	4.37	4.21
	70	70.6	4.22	4.53	70.2	4.03	4.60	69.8	3.85	4.67
	80	67.6	3.74	4.92	67.4	3.57	5.01	67.2	3.42	5.11
47	60	61.4	4.17	3.94	61.5	4.02	3.97	61.6	3.88	4.01
	70	58.8	3.66	4.33	59.0	3.53	4.38	59.1	3.42	4.43
	80	56.2	3.23	4.73	56.4	3.12	4.78	56.6	3.02	4.84
40	60	54.6	3.76	3.88	54.8	3.66	3.88	55.1	3.57	3.88
	70	52.2	3.30	4.26	52.2	3.19	4.28	52.3	3.10	4.30
	80	49.7	2.90	4.65	49.6	2.80	4.69	49.5	2.70	4.73
30	60	44.5	3.17	3.74	44.9	3.11	3.72	45.3	3.06	3.70
	70	42.8	2.80	4.11	43.3	2.75	4.10	43.8	2.70	4.10
	80	41.1	2.48	4.48	41.7	2.44	4.49	42.3	2.40	4.51
17	60	33.4	2.46	3.60	33.3	2.41	3.54	33.2	2.36	3.48
	70	31.5	2.14	3.94	31.9	2.12	3.90	32.3	2.10	3.87
	80	29.6	1.87	4.26	30.5	1.87	4.26	31.5	1.88	4.26
10	60	30.1	2.24	3.55	30.6	2.24	3.49	31.2	2.24	3.43
	70	28.4	1.95	3.88	28.9	1.95	3.83	29.5	1.95	3.79
	80	26.6	1.70	4.21	27.2	1.70	4.18	27.8	1.69	4.15

UNIT DIMENSIONS AND ACCESS LOCATIONS

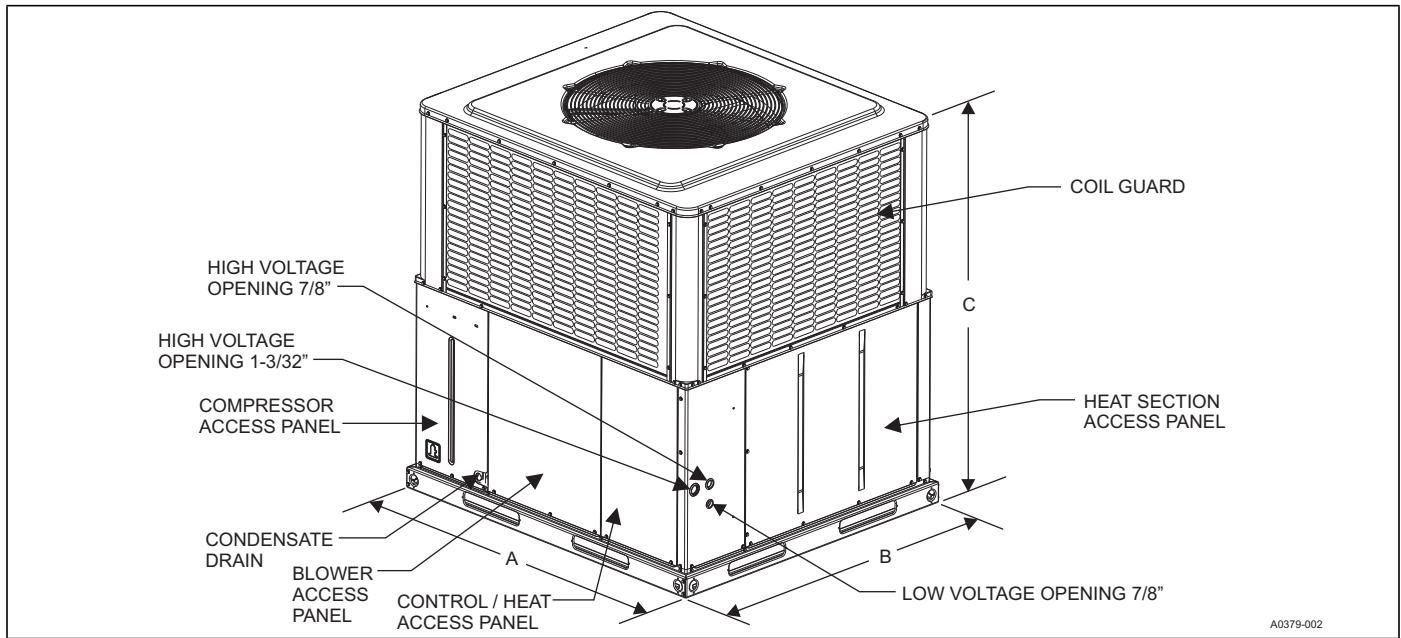

UNIT DIMENSIONS

Model	Dimensions		
	A	B	C
PHE6B3641	51-1/4	45-3/4	49
PHE6B4841	51-1/4	45-3/4	53
PHE6B6041	51-1/4	45-3/4	55

UNIT CLEARANCES

Direction	Distance (in.)	Direction	Distance (in.)
Top ¹	36	Incoming Power (Right Side)	36
Side Opposite Ducts	36	Left Side	24
Duct Panel	0	Bottom ^{2 3}	1

NOTES:

1. Minimum Clearance of 1inch all sides of supply air duct for the first 3 foot of duct for 20 & 25 kW., zero inches there after. For all other heaters, zero inch clearance all sides for entire length of duct.
 2. Units must be installed outdoors. Over hanging structure or shrubs should not obscure outdoor air discharge outlet.
 3. Units may be installed on combustible floors made from wood or class A, B or C roof covering materials.
- Note:** For units applied with a roof curb, the minimum clearance may be reduced from 1 inch to 1/2 inch? between combustible roof curb material and this supply air duct.

INDOOR BLOWER SPECIFICATIONS

Model	Motor				
	HP	RPM	EFF.	SF	Frame
PHE6B3641	1/2	Variable	0.8	1.0	48
PHE6B4841	1	Variable	0.8	1.0	48
PHE6B6041	1	Variable	0.8	1.0	48

COOLING SOUND PERFORMANCE

Model (Tons)	Sound Rating ¹ dB (A)	Octave Band Centerline Frequency (Hz)						
		125	250	500	1000	2000	4000	8000
PHE6B3641	73.2	61.8	63.2	60.5	64.4	58.9	53.4	45.9
PHE6B4841	74.0	62.0	62.0	60.9	64.7	60.1	56.6	49.2
PHE6B6041	74.1	65.9	61.8	60.8	63.5	58.7	55.5	48.3

NOTE:

1. Rated in accordance with AHRI Standard 270.

HEATING SOUND PERFORMANCE

Model (Tons)	Sound Rating ¹ dB (A)	Octave Band Centerline Frequency (Hz)						
		125	250	500	1000	2000	4000	8000
PHE6B3641	72.8	60.1	62.5	60.4	64.5	58.8	53.0	46.0
PHE6B4841	74.6	66.0	63.3	61.1	64.6	60.2	56.4	48.9
PHE6B6041	73.7	61.6	59.4	60.5	63.6	58.7	55.1	51.4

NOTE:

1. Rated in accordance with AHRI Standard 270.

RECOMMENDED BLOWER SPEED FOR ELECTRIC HEAT

Model	Heater kW				
	10	15	18	20	25
PHE6B36	C (ML)	A (HI)	--	--	--
PHE6B48	D (LO)	C (ML)	B (MH)	A (HI)	--
PHE6B60	D (LO)	D (LO)	C (ML)	B (MH)	A (HI)

NOTE:

1. The recommended HEAT speed selections above will give approximately a 45 degree temperature rise at 0.3" static with 460V power supply. If lower or higher heating airflow is desired, or if duct static or voltage are different than specified, other speed taps may be used.

ELECTRICAL DATA - 460-3-60 - SINGLE SOURCE POWER

Model	Compressor			OD Fan Motor	Blower Motor	Electric Heat Option				MCA ¹ (Total Unit)	Max Fuse ² or Breaker ³ Size (Total Unit)	MCA ¹ (Unit Less Heater)	Max Fuse ² or Breaker ³ Size (Unit Less Heater)	MCA ¹ Unit (Heater Only)	Max Fuse ² or Breaker ³ Size (Heater Only)
						Heater Kit ⁴	Heater kW	Stages	Heater Amps						
RLA	LRA	MCC	FLA	FLA											
PHE6B36	5.7	38.0	8.9	0.9	1.9	none	--	--	--	9.9	15	9.9	15	-	-
						6HK06501046	8.8	1	11.0	23.7	25	9.9	15	13.8	15
						6HK06501546	13.2	1	16.6	30.6	35	9.9	15	20.7	25
PHE6B48	6.4	41.0	10.0	0.9	3.3	none	--	--	--	12.2	15	12.2	15	-	-
						6HK06501046	8.8	1	11.0	26.0	30	12.2	15	13.8	15
						6HK06501546	13.2	1	16.6	32.9	35	12.2	15	20.7	25
						6HK06501846	15.9	1	20.0	37.1	40	12.2	15	24.9	25
						6HK06502046	17.6	1	22.1	39.8	40	12.2	15	27.6	30
PHE6B60	7.6	52.0	11.9	0.9	3.3	none	--	--	--	13.7	20	13.7	20	-	-
						6HK06501046	8.8	1	11.0	27.5	30	13.7	20	13.8	15
						6HK06501546	13.2	1	16.6	34.4	35	13.7	20	20.7	25
						6HK06501846	15.9	1	20.0	38.6	40	13.7	20	24.9	25
						6HK06502046	17.6	1	22.1	41.3	45	13.7	20	27.6	30
						6HK06502546	22.0	1	27.6	48.2	50	13.7	20	34.5	35

NOTES:

- Single-source power MCA and MOP requirements are given here for reference if the unit is to be installed with a field-installed single-point power modification.

1. MCA = Minimum Circuit Ampacity.
2. Maximum Over Current Protection per standard UL 1995.
3. Fuse or HACR circuit breaker to be field installed.
4. Single Point Conversion Kit required.

ELECTRICAL DATA FOR 460-3-60 MULTI SOURCE POWER

Model	Compressor			OD Fan Motor	Blower Motor	Electric Heat Option				MCA ¹ Amps	Max Fuse ² or Breaker ³ Size	MCA ¹ Amps	Max Fuse ² or Breaker ³ Size
						Heater Kit	Heater kW	Stages	Heater Amps				
RLA	LRA	MCC	FLA	FLA									
PHE6B36	5.7	38.0	8.9	0.9	1.9	none	--	--	--	9.9	15.0	--	--
						6HK06501046	8.8	1.0	11.0	9.9	15.0	13.8	15.0
						6HK06501546	13.2	1.0	16.6	9.9	15.0	20.7	25.0
PHE6B48	6.4	41.0	10.0	0.9	3.3	none	--	--	--	12.0	15.0	--	--
						6HK06501046	8.8	1.0	11.0	12.0	15.0	13.8	15.0
						6HK06501546	13.2	1.0	16.6	12.0	15.0	20.7	25.0
						6HK06501846	15.9	1.0	20.0	12.0	15.0	24.9	25.0
						6HK06502046	17.6	1.0	22.1	12.0	15.0	27.6	30.0
PHE6B60	7.6	52.0	11.9	0.9	3.3	none	--	--	--	13.5	20.0	--	--
						6HK06501046	8.8	1.0	11.0	13.5	20.0	13.8	15.0
						6HK06501546	13.2	1.0	16.6	13.5	20.0	20.7	25.0
						6HK06501846	15.9	1.0	20.0	13.5	20.0	24.9	25.0
						6HK06502046	17.6	1.0	22.1	13.5	20.0	27.6	30.0
						6HK06502546	22.0	1.0	27.6	13.5	20.0	34.5	35.0

NOTES:

1. MCA = Minimum Circuit Ampacity.
2. Maximum Over Current Protection per standard UL 1995.
3. Fuse or HACR circuit breaker to be field installed.

SINGLE-POINT WIRING KIT PART NUMBERS

Unit Model Number	Voltage	Heater Kit	Single-Point Wiring Kit	Unit Fuse Size (Amps)	Heater Fuse Size (Amps)
PHE6B3641	460-3-60	6HK06501046	S1-2SPWK036	15	15
		6HK06501546	S1-2SPWK036	15	25
PHE6B4841	460-3-60	6HK06501046	S1-2SPWK036	15	15
		6HK06501546	S1-2SPWK036	15	25
		6HK06501846	S1-2SPWK036	15	25
		6HK06502046	S1-2SPWK036	15	30
PHE6B6041	460-3-60	6HK06501046	S1-2SPWK036	20	15
		6HK06501546	S1-2SPWK036	20	25
		6HK06501846	S1-2SPWK036	20	25
		6HK06502046	S1-2SPWK036	20	30
		6HK06502546	S1-2SPWK037	20	35

NOTES:

* - the 460 volt 20kW and 25kW heater kits include circuit breakers, so no fuse is needed

WEIGHTS & DIMENSIONS

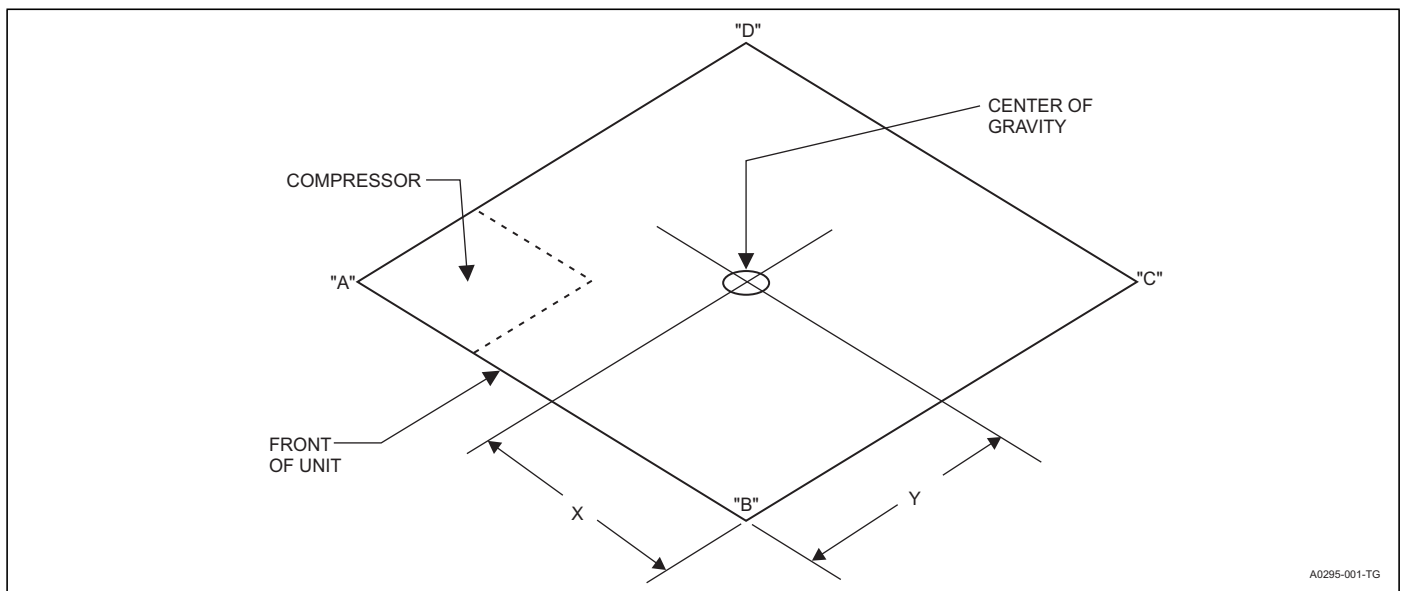

WEIGHTS & DIMENSIONS

Model	Weight (lbs.)		Center of Gravity		4 Point Load Location (lbs.)			
	Shipping	Operating	X	Y	A	B	C	D
PHE6B3641	453	448	29	15	158	108	101	86
PHE6B4841	501	496	29	15	168	130	119	84
PHE6B6041	528	523	30	15	177	136	128	87

AIRFLOW PERFORMANCE - SIDE DUCT APPLICATION

Model	Jumper Position		External Static Pressure (Inches WC)									
			0.1	0.2	0.3	0.4	0.5	0.6	0.7	0.8	0.9	1.0
			SCFM	SCFM	SCFM	SCFM	SCFM	SCFM	SCFM	SCFM	SCFM	SCFM
PHE6B36	High Cool/Heat	A	1621	1531	1454	1371	1299	1223	1138	1039	966	869
		B	1507	1418	1339	1268	1200	1130	1059	981	911	837
		C	1410	1288	1209	1132	1054	982	904	831	755	691
		D	1224	1137	1052	978	902	824	748	682	611	549
	Low Cool/Heat	A	1060	964	879	795	706	623	538	459	397	331
		B	1017	919	830	742	650	570	487	415	344	276
		C	974	875	780	688	595	517	436	371	291	222
		D	813	721	617	509	404	323	237	171	81	81
	Electric Heat	A	1264	1179	1092	1017	942	865	787	735	662	598
		B	1147	1056	972	895	815	735	657	578	511	450
		C	1003	904	813	724	632	552	470	400	327	258
		D	902	802	700	602	504	429	348	292	201	201
PHE6B48	High Cool/Heat	A	1893	1845	1804	1764	1717	1672	1625	1576	1528	1473
		B	1785	1737	1694	1650	1597	1547	1501	1452	1392	1335
		C	1703	1649	1595	1546	1491	1436	1385	1327	1264	1200
		D	1654	1596	1535	1483	1427	1370	1315	1252	1187	1118
	Low Cool/Heat	A	1304	1225	1152	1072	998	893	842	785	731	648
		B	1265	1183	1109	1026	950	839	789	733	681	596
		C	1200	1116	1039	952	874	757	707	652	599	512
		D	1304	1225	1152	1072	998	893	842	785	731	648
	Electric Heat	A	1423	1351	1281	1211	1143	1056	1002	941	883	804
		B	1304	1225	1152	1072	998	893	842	785	731	648
		C	1125	1039	957	870	791	672	623	564	507	416
		D	1000	912	820	733	652	529	481	418	354	255
PHE6B60	High Cool/Heat	A	2305	2255	2215	2164	2103	2074	2024	1965	1910	1867
		B	2186	2144	2101	2059	2003	1956	1930	1886	1837	1796
		C	2007	1963	1919	1873	1828	1781	1731	1693	1646	1606
		D	1935	1887	1840	1788	1754	1702	1645	1609	1560	1519
	Low Cool/Heat	A	1675	1627	1566	1512	1473	1423	1374	1324	1278	1234
		B	1523	1463	1405	1350	1302	1248	1196	1143	1089	1044
		C	1369	1307	1251	1196	1141	1082	1024	964	907	849
		D	1413	1352	1295	1240	1187	1130	1073	1015	959	905
	Electric Heat	A	1762	1724	1661	1608	1574	1526	1478	1429	1390	1341
		B	1479	1418	1361	1306	1256	1201	1147	1092	1037	989
		C	1369	1307	1251	1196	1141	1082	1024	964	907	849
		D	1209	1147	1084	1022	957	897	835	777	722	669

NOTES:

1. Airflow tested with dry coil conditions, without air filters, at 460 volts.
2. Applications above 0.8" w.c. external static pressure are not recommended.
3. Brushless DC high efficiency standard ECM blower motor used for all indoor blower assemblies.
4. Minimal variations in airflow performance data results from using downflow duct applications. Data above may be used in those cases.
5. Heating applications tested at 0.50" w.c. esp, and cooling applications tested at 0.30" w.c. esp per standards.

ADDITIONAL STATIC RESISTANCE

Size (Tons)	CFM	Wet Indoor Coil	Economizer ¹	Filter/Frame Kit
36 (3.0)	700	0.01	0.00	0.04
	800	0.02	0.01	0.06
	900	0.03	0.01	0.08
	1000	0.04	0.01	0.10
	1100	0.05	0.01	0.13
	1200	0.06	0.02	0.16
	1300	0.07	0.03	0.17
	1400	0.08	0.04	0.18
48 (4.0)	1100	0.02	0.02	0.04
	1200	0.03	0.02	0.04
	1300	0.04	0.02	0.05
	1400	0.05	0.03	0.05
	1500	0.06	0.04	0.06
	1600	0.07	0.04	0.07
	1700	0.07	0.04	0.08
	1800	0.08	0.04	0.09
60 (5.0)	1900	0.09	0.05	0.10
	2000	0.09	0.05	0.11
	1100	0.02	0.02	0.04
	1200	0.03	0.02	0.04
	1300	0.04	0.02	0.05
	1400	0.05	0.03	0.05
	1500	0.06	0.04	0.06
	1600	0.07	0.04	0.07
1700	0.07	0.04	0.08	
1800	0.08	0.04	0.09	
1900	0.09	0.05	0.10	
2000	0.09	0.05	0.11	

1. The pressure drop through the economizer is greater for 100% outdoor air than for 100% return air. If the resistance of the return air duct is less than 0.25 IWG, the unit will deliver less CFM during full economizer operation. Filter pressure drop based on standard filter media tested at velocities not to exceed 300 ft/min.

BOTTOM DUCT DIMENSIONS (Inches)

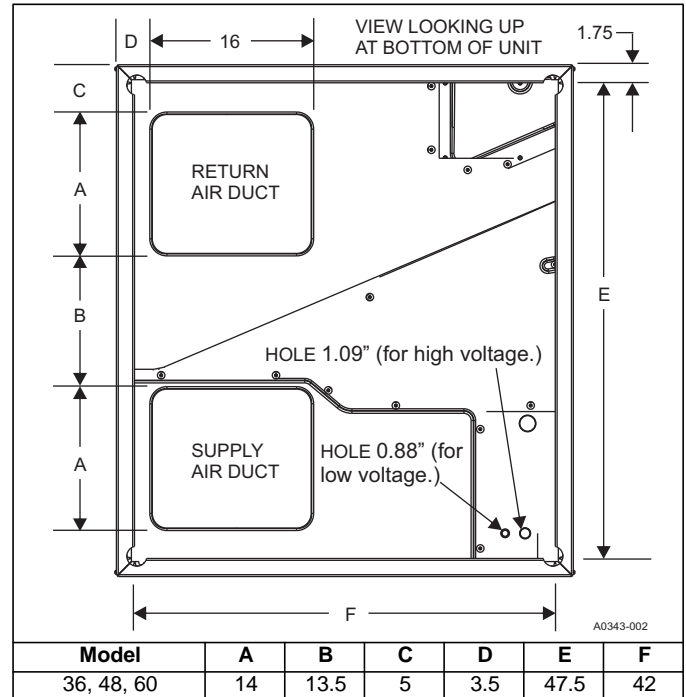

REAR DUCT DIMENSIONS (Inches)

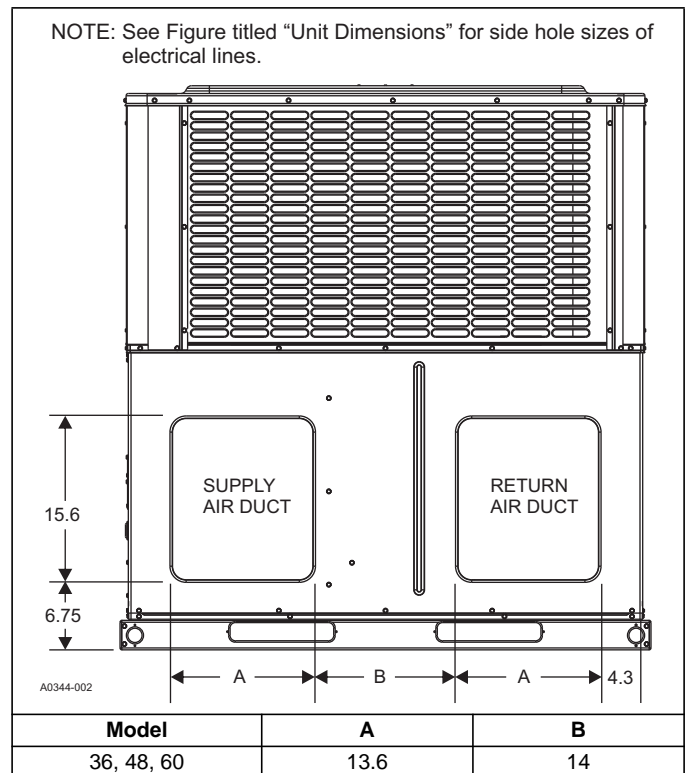

UNIT TYPICAL DUCT APPLICATIONS

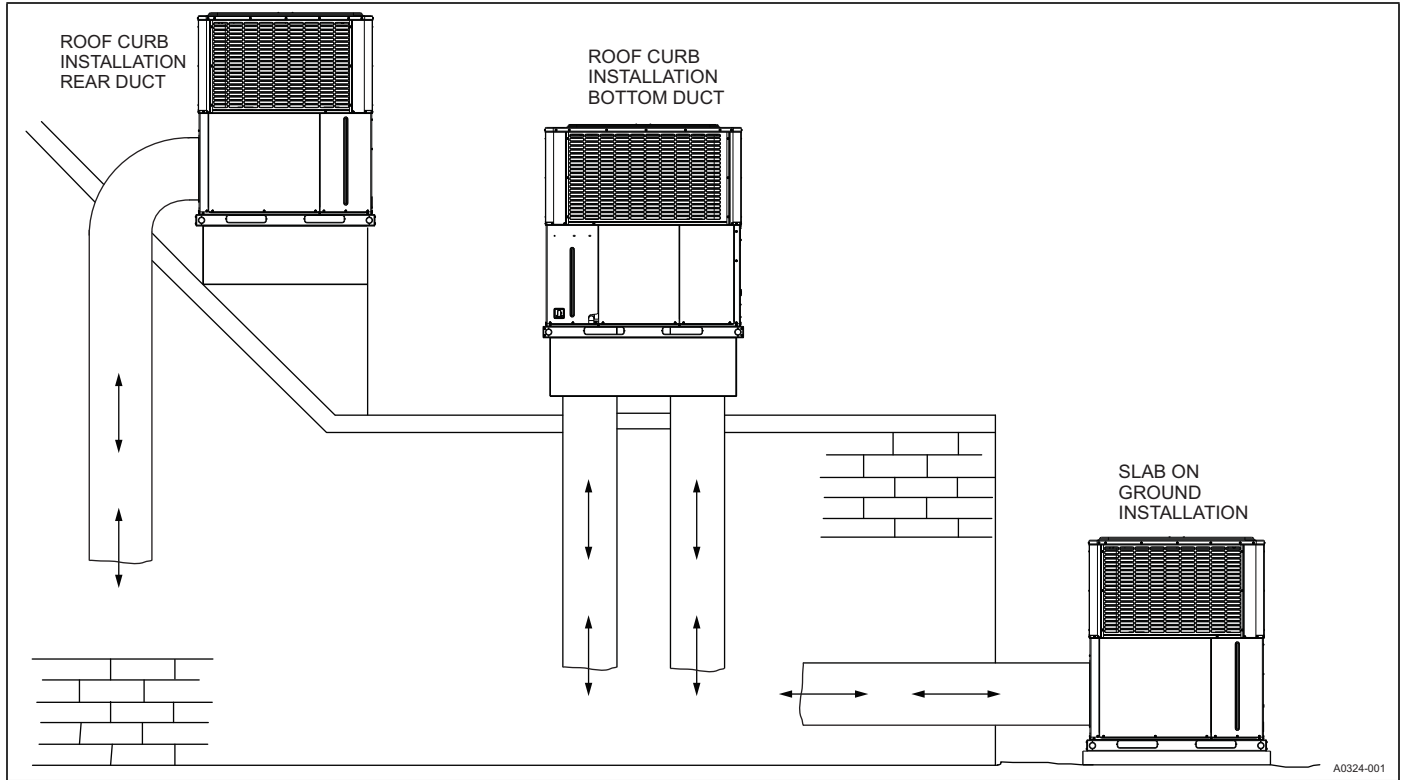

UNIT TYPICAL SLAB ON GROUND INSTALLATION

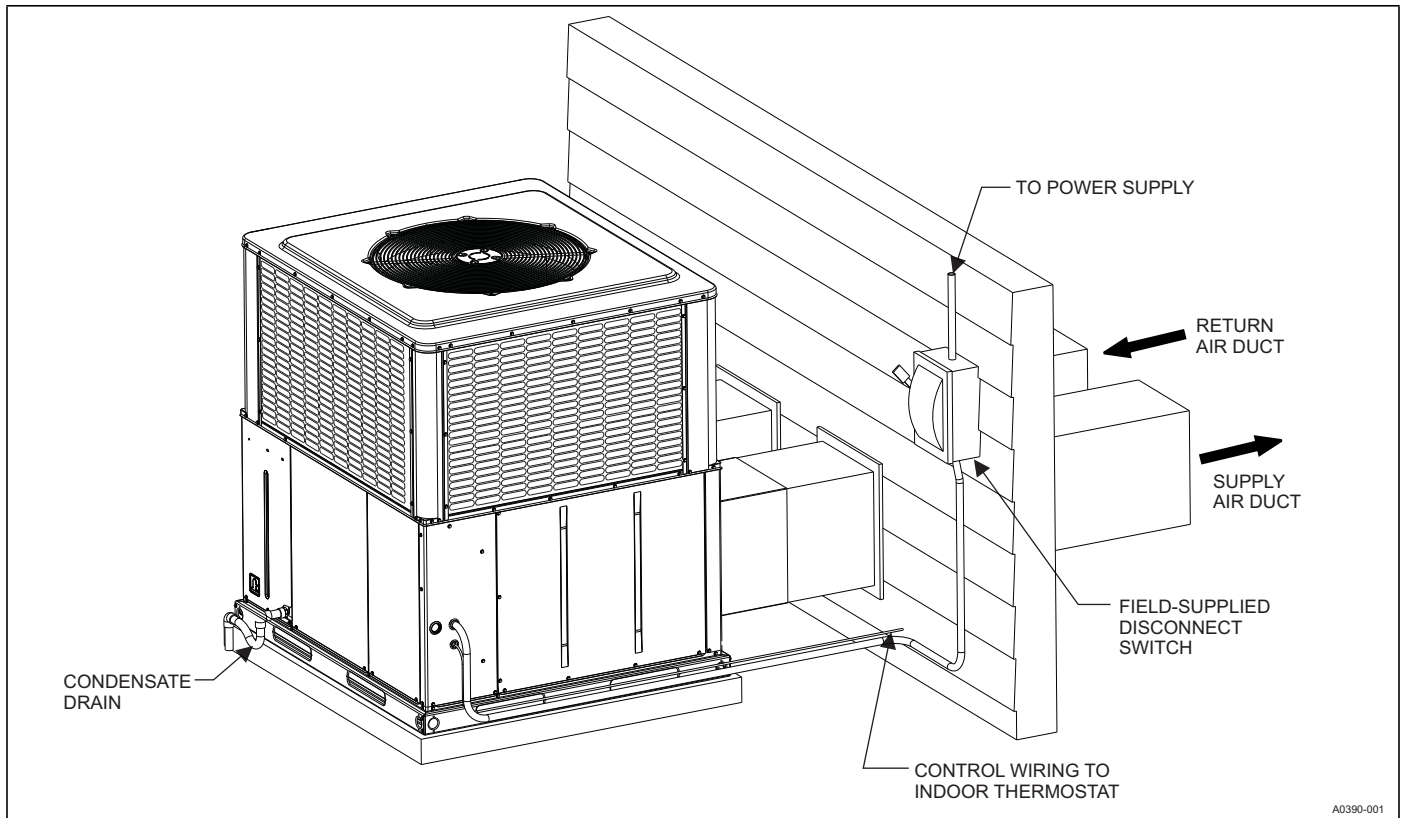

UNIT TYPICAL ROOF CURB INSTALLATION

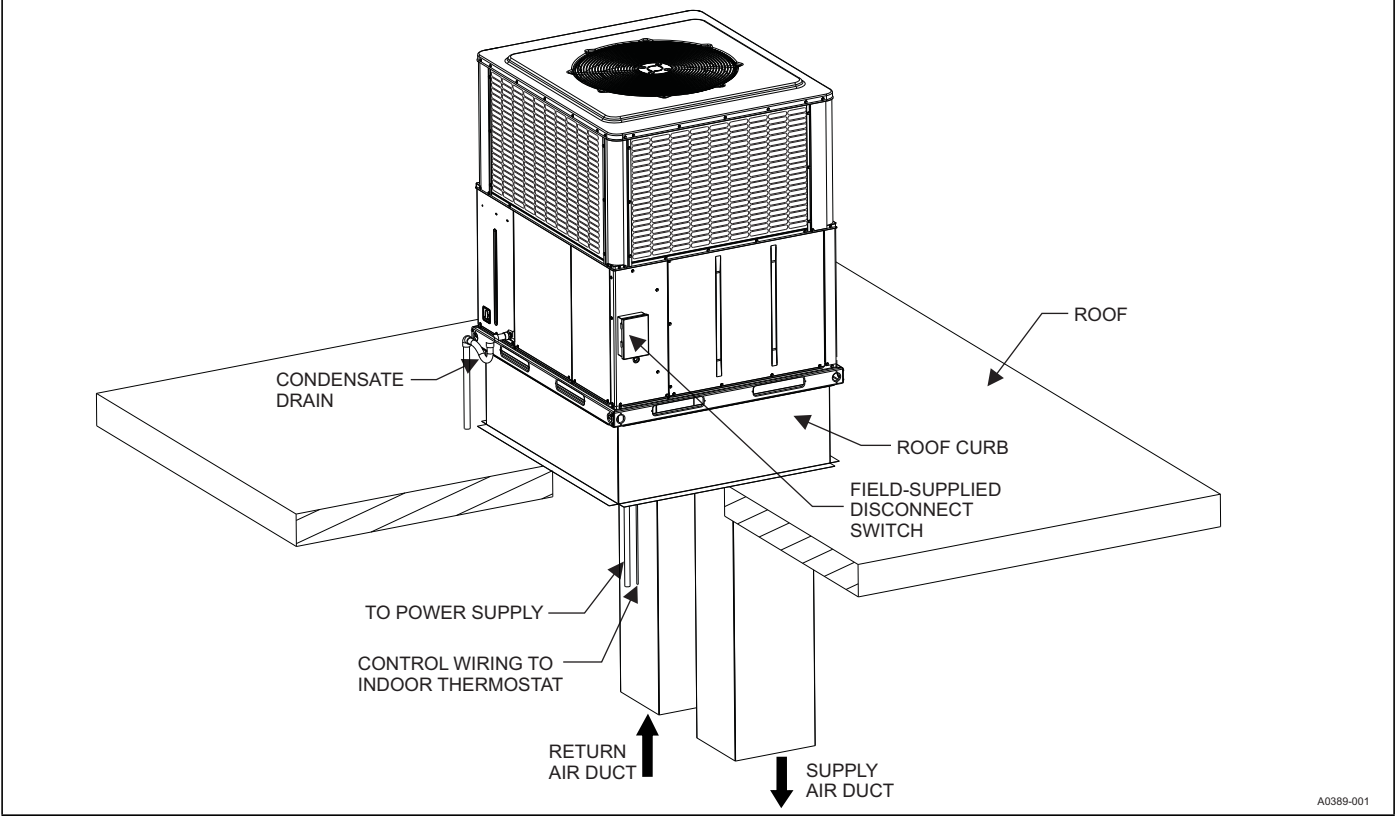

NOTES